



Fire assessment report



Cable and metal pipe penetrations protected with H B Fuller FIRESOUND sealant

Sponsor: H B Fuller Australia Pty Ltd

Report number: 27001 Revision: R4.1 Project reference number: FAS200117

Issued date: 18 March 2021 Expiry date: 31 January 2026

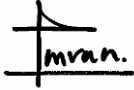
Quality management

Version	Date	Information about the report			
27001-00	Issue: 30/03/2012	Reason for issue	Initial Issue		
		Prepared by	Reviewed by	Authorised by	
		Name	S. Hu	K. G. Nicholls	N/A
27001-01	Issue: 28/02/2013	Reason for issue	Typographical amendment		
		Prepared by	Reviewed by	Authorised by	
		Name	S. Hu	K. G. Nicholls	N/A
27001-02	Issue: 9/03/2016	Reason for issue	Revised to consider applicability of AS 1530.4:2014		
		Prepared by	Reviewed by	Authorised by	
		Name	K. G. Nicholls	D. Nicholson	N/A
27001-03	Issue: 11/03/2016	Reason for issue	Revised expiry date		
		Prepared by	Reviewed by	Authorised by	
		Name	K. G. Nicholls	D. Nicholson	N/A
R4.0	Issue: 31/01/2021	Reason for issue	Revalidation and revision to include additional test data.		
		Prepared by	Reviewed by	Authorised by	
		Name	Sashini Sue	Imran Ahamed	Mahmoud Akl
R4.1	Issue: 18/03/2021	Reason for issue	Include additional information as requested from client		
		Prepared by	Reviewed by	Authorised by	
	Expiry: 31/01/2026	Name	Sashini Sue	Imran Ahamed	Mahmoud Akl
	Signature	Sashini Heparacheti			

Executive summary

This report documents the findings of the assessment undertaken to determine the likely fire resistance level (FRL) of various penetration systems if tested in accordance with AS 1530.4:2014 and assessed in accordance with AS 4072.1:2005.

The assessment references fire test reports WFRA 41257.1 and FRT200220 R1.0 to establish the fire resistance performance of various cable and metal pipe penetrations in a 150 mm thick Aerated Autoclaved Concrete (AAC)/ concrete wall and a 150 mm thick concrete floor - protected with H B Fuller Firesound sealant.

The analysis in section 5 of this report found that the proposed penetration systems when protected with H B Fuller Firesound sealant are likely to achieve the fire resistance level (FRL) as shown in Table 1, Table 2 and Table 3, if tested in accordance with AS 1530.4:2014 and assessed in accordance with AS 4072.1:2005.

Table 1 Assessment outcome of proposed services penetrating a 150 mm thick AAC/concrete wall

Item no.	Service	Sealing system	FRL
1	AS 1530.4:2014 Appendix D1 cables	The Firesound sealant must be applied to a depth of 10 mm on both the exposed and unexposed side from the separating element. A 50 mm × 50 mm fillet of the sealant must also be applied around the service on both exposed and unexposed sides of the separating element.	-/180/90
2	AS 1530.4:2014 Appendix D2 cables		-/180/120
3	PVC insulated copper cable	The Firesound sealant must be applied to a depth of 10 mm on both the exposed and unexposed side from the separating element. A 30 mm × 30 mm fillet of the sealant must also be applied around the service on both exposed and unexposed sides of the separating element.	-/180/180
4	22 mm (ID) steel sprinkler pipe with a wall thickness of 3 mm		-/180/180
5	32 mm (ID) steel sprinkler pipe with a wall thickness of 3 mm	The Firesound sealant must be applied to a depth of 10 mm on both the exposed and unexposed side from the separating element. A 50 mm × 50 mm fillet of the sealant must also be applied around the service on both exposed and unexposed sides of the separating element.	-/180/180
6	100 mm (ID) copper pipe with a wall thickness of 2 mm		-/180/-
7	80 mm (ID) steel sprinkler pipe with a wall thickness of 4 mm		-/180/30

Table 2 Assessment outcome of proposed cable services penetrating a 150 mm concrete floor

Item no.	Cable Services	Sealing system	FRL
1	AS 1530.4:2014 Appendix D1 cables	The Firesound sealant must be applied to a depth of 10 mm on both the exposed and unexposed side from the separating element. A 50 mm × 50 mm fillet of the sealant must also be applied around the service on both exposed and unexposed sides of the separating element.	-/240/60
2	AS 1530.4:2014 Appendix D2 cables		-/180/90
3	PVC insulated copper cable		-/180/120

Table 3 Assessment outcome of proposed metal pipe services penetrating a 150 mm concrete floor

Item no.	Metal pipe (mm)	Material	Wall thickness (mm)	Sealing system	FRL
1	22 (ID)	Steel	3.0	The Firesound sealant must be applied to a depth of 20 mm on both the exposed and unexposed side from the separating element. A 50 mm × 50 mm fillet of the sealant must also be applied around the service on both exposed and unexposed sides of the separating element.	-/240/90
2	32 (ID)	Steel	3.0	The Firesound sealant must be applied to a depth of 10 mm on both the exposed and unexposed side from the separating element. A 50 mm × 50 mm fillet of the sealant must also be applied around the service on both exposed and unexposed sides of the separating element.	-/240/120
3	80 (ID)	Steel	4.0		-/240/15
4	DN 32	Copper, brass, steel	0.91		-/240/120
5	DN 40 -DN 65	Copper, brass, steel	0.91		-/240/15
6	DN 80 – DN 100	Copper, brass, steel	1.22		-/240/15
7	100 (ID)	Copper	2.0		-/240/15
8	DN 125	Copper, steel	1.42		The Firesound sealant must be applied to a depth of 20 mm on both the exposed and unexposed side from the separating element. A 50 mm × 50 mm fillet of the sealant must also be applied around the service on both exposed and unexposed sides of the separating element.
9	DN 150	Copper, steel	1.63	-/180/15	

The variations and outcome of this assessment are subject to the limitations and requirements described in sections 2, 3 and 6 of this report. The results of this report are valid until 31 January 2026.

Contents

1.	Introduction	6
2.	Framework for the assessment	6
2.1	Assessment approach	6
2.2	Compliance with the National Construction Code	7
2.3	Declaration	7
3.	Limitations of this assessment	7
4.	Description of the specimen and variations	8
4.1	System description	8
4.2	Referenced test data	8
4.3	Variations to the tested systems	8
4.4	Purpose of the test	8
4.5	Schedule of components	9
5.	Assessment of cables and metal pipes	15
5.1	Description of variation	15
5.2	Methodology	15
5.3	Assessment	15
5.4	Conclusion	19
6.	Validity	21
Appendix A	Drawings and additional information	22
Appendix B	Summary of supporting test data	23

1. Introduction

This report documents the findings of the assessment undertaken to determine the likely fire resistance level (FRL) of cable and metal pipe penetrations in a 150 mm thick AAC/concrete steel wall and a 150 mm thick concrete floor protected with H B Fuller FIRESOUND sealant – if tested in accordance with AS 1530.4:2014¹ and assessed in accordance with AS 4072.1:2005².

This assessment was carried out at the request of H B Fuller Australia Pty Ltd. The sponsor details are included in Table 4.

Table 4 Sponsor details

Sponsor	Address
H B Fuller Australia Pty Ltd	16-22 Redgum Drive Dandenong South VIC 3175 Australia

2. Framework for the assessment

2.1 Assessment approach

An assessment is an opinion about the likely performance of a component or element of structure if it was subject to a standard fire test.

No specific framework, methodology, standard or guidance documents exists in Australia for doing these assessments. We have therefore followed the 'Guide to undertaking technical assessments of the fire performance of construction products based on fire test evidence' prepared by the Passive Fire Protection Forum (PFPF) in the UK in 2019³.

This guide provides a framework for undertaking assessments in the absence of specific fire test results. Some areas where assessments may be offered are:

- Where a modification is made to a construction which has already been tested.
- The interpolation or extrapolation of results of a series of fire resistance tests, or utilisation of a series of fire test results to evaluate a range of variables in a construction design or a product.
- Where, for various reasons – eg size or configuration – it is not possible to subject a construction or a product to a fire test.

Assessments will vary from relatively simple judgements on small changes to a product or construction through to detailed and often complex engineering assessments of large or sophisticated constructions.

This assessment uses established empirical methods and our experience of fire testing similar products to extend the scope of application by determining the limits for the design based on the tested constructions and performances obtained. The assessment is an evaluation of the potential fire resistance performance if the elements were to be tested in accordance with AS 1530.4:2014.

This assessment has been written using appropriate test evidence generated at accredited laboratories to the relevant test standard. The supporting test evidence has been deemed appropriate to support the manufacturer's stated design.

¹ Standards Australia, 2014, Methods for fire tests on building materials, components and structures – Part 4: Fire-resistance tests for elements of construction, AS1530.4:2014, Standards Australia, NSW.

² Standards Australia, 2005, Components for the protection of openings in fire-resistant separating elements – Part 1: Service penetrations and control joints, AS 4072.1:2005, Standards Australia, NSW.

³ Passive Fire Protection Forum (PFPF), 2019, Guide to undertaking technical assessments of the fire performance of construction products based on fire test evidence, Passive Fire Protection Forum (PFPF), UK.

2.2 Compliance with the National Construction Code

This assessment report has been prepared to meet the evidence of suitability requirements of the National Construction Code Volumes One and Two – Building Code of Australia (NCC) 2019 Amendment 1⁴ under A5.2 (1) (d) and 2016 under specification A2.3, including amendments.

This assessment has been written in accordance with the general principles outlined in EN 15725:2010⁵ for extended application reports on the fire performance of construction products and building elements. It also references test evidence for meeting a performance requirement or deemed to satisfy (DTS) provisions of the NCC under A5.4 for fire resistance levels as applicable to the assessed systems.

2.3 Declaration

The 'Guide to undertaking technical assessments of the fire performance of construction products based on fire test evidence' prepared by the PFPF in the UK requires a declaration from the client. By accepting our fee proposal on 15 April 2020, H B Fuller Australia Pty Ltd confirmed that:

- To their knowledge the component or element of structure, which is the subject of this assessment, has not been subjected to a fire test to the standard against which this assessment is being made.
- They agree to withdraw this assessment from circulation if the component or element of structure is the subject of a fire test by a test authority in accordance with the standard against which this assessment is being made and the results are not in agreement with this assessment.
- They are not aware of any information that could adversely affect the conclusions of this assessment and – if they subsequently become aware of any such information – they agree to ask the assessing authority to withdraw the assessment.

3. Limitations of this assessment

- The scope of this report is limited to an assessment of the variations to the tested systems described in section 4.3.
- This report details the methods of construction, test conditions and assessed results that are expected if the systems were tested in accordance with AS 1530.4:2014 and assessed in accordance with AS 4072.1:2005.
- The results of this assessment are applicable to fire exposure from below for concrete floors with thicknesses of 150 mm or greater (section 5.3.2 and section 5.3.3) and from any side of the steel reinforced CSR Hebel Powerpanel™ wall system with thickness 150 mm or greater (section 5.3.1).
- This report is only valid for the assessed systems and must not be used for any other purpose. Any changes with respect to size, construction details, loads, stresses, edge or end conditions – other than those identified in this report – may invalidate the findings of this assessment. If there are changes to the system, a reassessment will need to be done by an Accredited Testing Laboratory (ATL).
- The documentation that forms the basis for this report is listed in Appendix A.
- This report has been prepared based on information provided by others. Warringtonfire has not verified the accuracy and/or completeness of that information and will not be responsible for any errors or omissions that may be incorporated into this report as a result.
- This assessment is based on the proposed systems being constructed under comprehensive quality control practices and following appropriate industry regulations and Australian Standards on quality of materials, design of structures, guidance on workmanship and the

⁴ National Construction Code Volume One – Building Code of Australia 2019 Amendment 1, Australian Building Codes Board, Australia.

⁵ European Committee for Standardization, 2010, Extended application reports on the fire performance of construction products and building elements, EN 15725:2010, European Committee for Standardization, Brussels, Belgium.

expert handling, placing and finishing of the products on site. These variables are beyond the control and consideration of this report.

4. Description of the specimen and variations

4.1 System description

Penetration services assessed in this assessment report include cables and metal pipes in a 150 mm thick AAC/concrete wall and a 150 mm thick concrete floor - protected with H B Fuller Firesound sealant on both sides. Firesound is a one part, water based construction sealant for sealing joints and penetrations where fire resistance is required.

Proposed systems include standard D1 cables, D2 cables, a PVC insulated copper cable and copper/brass/steel metal pipes in various diameters and thicknesses – in a 150 mm thick AAC/concrete wall wall and a 150 mm thick concrete floor - protected with H B Fuller Firesound sealant.

4.2 Referenced test data

The assessment of the variation to the tested system and the determination of the likely performance is based on the results of the fire tests documented in the reports summarised in Table 5. Further details of the tested system are included in Appendix B.

Table 5 Referenced test data

Report number	Test sponsor	Test date	Testing authority
FRT200220 R1.0	H B Fuller Australia Pty Ltd	23 November 2020	Warringtonfire
WFRA 41257.1	H B Fuller Australia Company Pty Ltd	11 October 2006	Warrington Fire Research Aust Pty Ltd

4.3 Variations to the tested systems

Identical systems have not been subject to a standard fire test. We have therefore assessed the systems using baseline test information for similar systems. The variations to the tested systems – together with the referenced standard fire tests – are described in Table 6.

Table 6 Variations to tested systems

Item number	Reference test	Description	Variations
1	FRT200220 R1.0 WFRA 41257.1	A set of standard communication cables and metal pipe configurations in a 150 mm thick concrete floor protected with H B Fuller Firesound sealant were tested in FRT200220 R1.0 in accordance with AS 1530.4:2014. WFRA 41257.1 test specimens consisted of cable and metal pipe penetrations in a 150 mm thick wall system protected with H B Fuller Firesound sealant tested in accordance with AS 1530.4:2005.	Based on the results of the referenced tests, it is proposed to determine the likely fire resistance performance of various cables and metal pipes protected with H B Fuller Firesound sealant in a 150 mm thick AAC/concrete wall and a 150 mm thick concrete floor - if tested in accordance with AS 1530.4:2014.

4.4 Purpose of the test

Section 2 of AS 1530.4:2014 specifies the general requirements for conducting fire resistance tests. Section 10 of AS 1530.4:2014 gives guidelines for determining the fire resistance of elements of construction penetrated by services.

As per section 10.3 of AS 1530.4:2014, the purpose of the test covering service penetrations and control joints is to assess-

- (a) The effect of the penetration or control joint on the integrity and insulation of the element.
- (b) Insulation or integrity failure of the penetrating service or control joint.

AS 4072.1:2005 (R2016) sets out the minimum requirements for the construction, installation and application of fire resistance tests to sealing systems.

4.5 Schedule of components

Table 7 outlines the schedule of components for the assessed systems subject to a fire test, as referenced in Appendix A. Figure 1 to Figure 7 show the assessed systems.

Table 7 Schedule of components of assessed systems

Item	Description	
1	Name	Sealant
	Material	H B Fuller FIRESOUND – Original grey
	Installation	Used on both exposed and unexposed sides of floor/wall and applied around the annular gap to the backing rod
2	Name	Foam backing rod
	Material	A density of approximately 20 kg/m ³
	Installation	Positioned in the annular gap with a nominal depth back from the slab surface.
3	Name	Floor construction
	Material	Normal weight or lightweight concrete
	Size	Minimum thickness of 150 mm
4	Name	Primer
	Material	Express 290D primer
	Installation	Pained on the inside of the hole and up to 30mm around the opening on both faces prior to sealing
5	Name	Power Cables (bundle)
	Material	PVC insulated copper cables
	Size	AS 1530.4:2014 Appendix D1 (Standard configuration)
6	Name	Telecommunications cable (single)
	Material	PVC insulated copper cable
	Size	A single 50 pair telecommunications cable, with each of the 100 wires in the cable having an outside diameter of 0.5 mm.
7	Name	Sprinkler pipe
	Material	Mild steel
	Size	Ø22 mm (ID-measured) × 3.0 mm (measured) wall thickness
8	Name	Sprinkler pipe
	Material	Mild steel
	Size	Ø32 mm (ID-measured) × 3.0 mm (measured) wall thickness
9	Name	Metal pipe
	Material	Copper
	Size	Ø100 mm (ID-measured) × 2.0mm (measured) wall thickness
10	Name	Sprinkler pipe
	Material	Mild steel

Item	Description	
	Size	Ø80 mm (ID-measured) × 4.0 mm (measured) wall thickness
11	Name	Telecommunication cables
	Material	PVC insulated copper cables
	Size	AS 1530.4:2014 Appendix D2 (standard configuration)
12	Name	Metal pipe
	Material	Copper, brass
	Size	DN 32 - DN 65, actual wall thickness 0.91 mm
13	Name	Metal pipe
	Material	Copper, brass
	Size	DN 80 - DN 100, actual wall thickness 1.22 mm
14	Name	Metal pipe
	Material	Copper
	Size	DN 125, actual wall thickness 1.42 mm
15	Name	Metal pipe
	Material	Copper
	Size	DN 150, actual wall thickness 1.63 mm
16	Name	Wall system
	Material	Aerated Autoclaved Concrete or Concrete
	Size	Minimum thickness of 150 mm

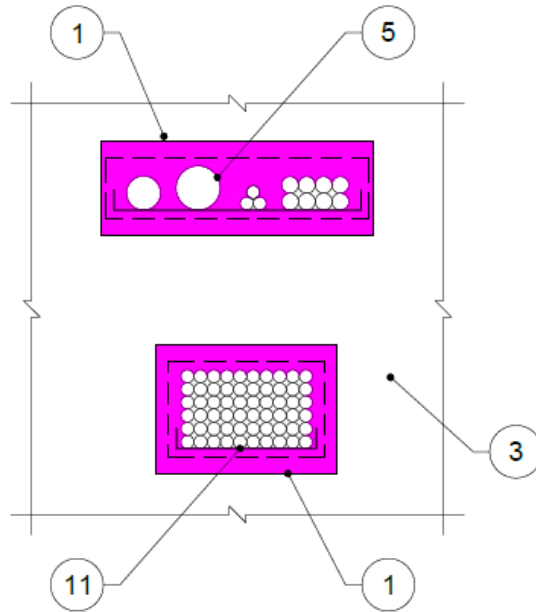

Figure 1 Plan view of D1 and D2 cable services in floor

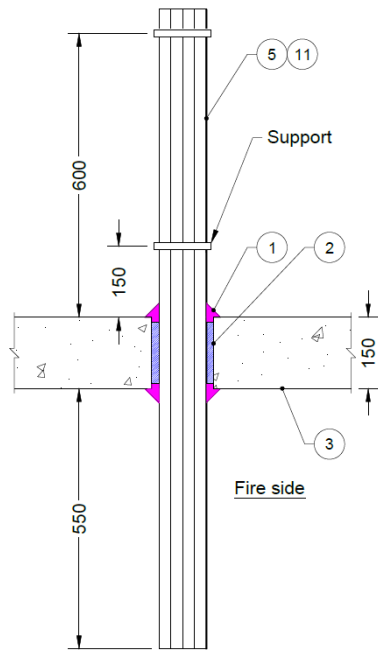

Figure 2 Elevation view of D1 and D2 cable services in floor

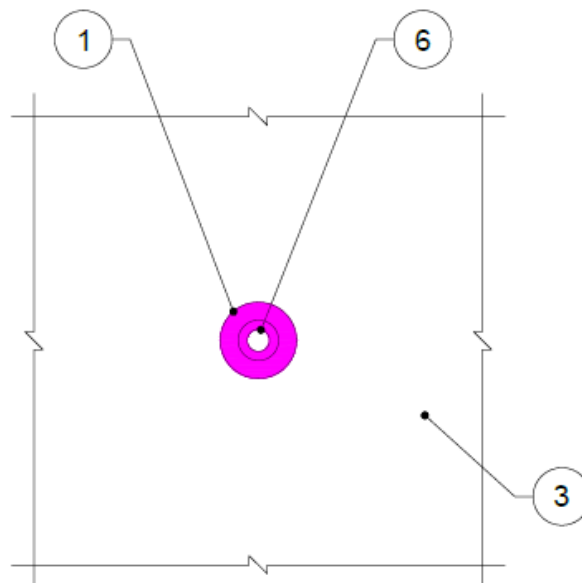

Figure 3 Plan view of single communication cable in floor

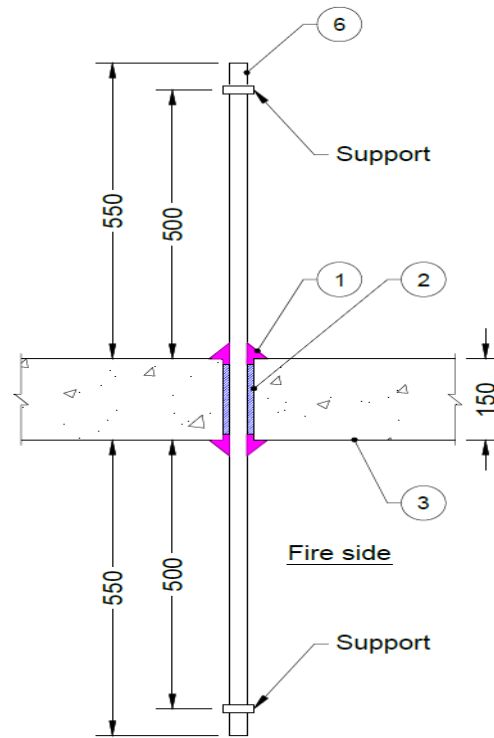

Figure 4 Elevation view of single communication cable in floor

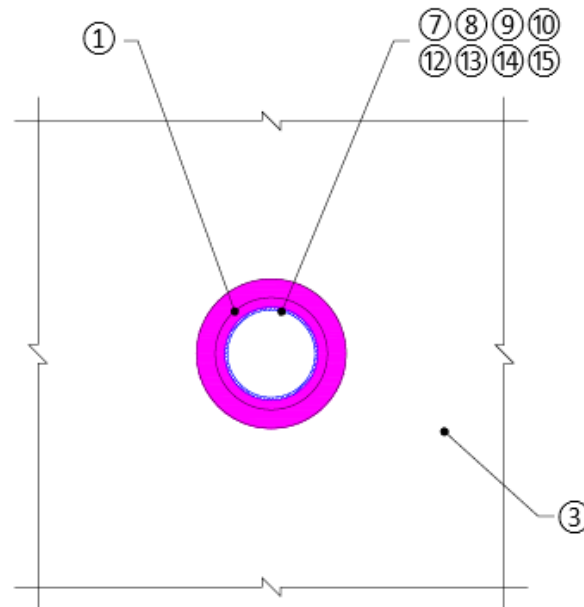

Figure 5 HB Fuller FIRESOUND sealant system with metal pipes in floor

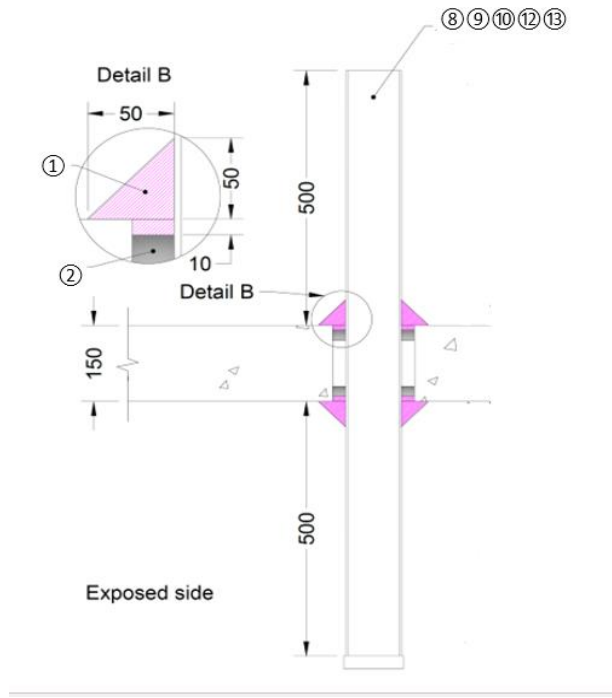

Figure 6 Elevation view of metal pipe penetrations in floor

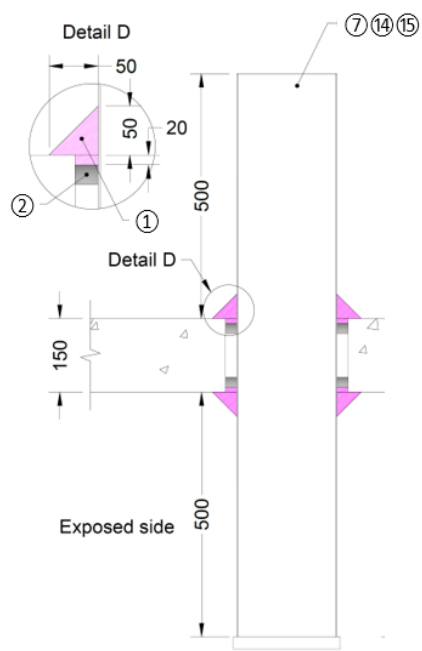

Figure 7 Elevation view of metal pipe penetrations in floor

5. Assessment of cables and metal pipes

5.1 Description of variation

WFRA 41257.1 test includes FRL results of cable and metal pipe penetrations with various configurations protected by H B Fuller Firesound sealant on 150 mm thick steel reinforced CSR Hebel Powerpanel™ walls tested in accordance with AS 1530.4:2005. Test specimen in FRT200220 R1.0 includes standard cable configurations and metal pipes protected by H B Fuller Firesound sealant in a 150 mm thick concrete floor tested in accordance with AS 1530.4:2014.

This assessment was done to determine the likely FRL performance of various telecommunication cables, power cables and metal pipes in a 150 mm thick AAC/concrete wall and a 150 mm thick concrete floor protected by H B Fuller Firesound sealant – if tested in accordance with AS 1530.4:2014 and assessed in accordance with AS 4072.1:2005 – based on baseline test results from FRT200220 R1.0 and WFRA 41257.1.

5.2 Methodology

The method of assessment used is summarised in Table 8.

Table 8 Method of assessment

Assessment method	
Level of complexity	Intermediate assessment
Type of assessment	Qualitative and Comparative

5.3 Assessment

5.3.1 Relevance of WFRA 41257.1 test data with respect to AS 1530.4:2014

The fire resistance tests WFRA 41257.1 was conducted in accordance with AS 1530.4:2005, which differs from AS 1530.4:2014. The effect these differences have on fire resistance performance of the referenced test specimens is discussed below.

Furnace temperature measurement

The specifications for furnace thermocouples in AS 1530.4:2014 are the same as those specified in AS 1530.4:2005.

Furnace temperature regime

AS 1530.4:2005 and AS 1530.4:2014 specify furnace temperature to follow the following trend:

$$T_{AS1530.4:2014} = 345 \log_{10}(8t + 1) + 20$$

The parameters outlining the accuracy of control of the furnace temperature in AS 1530.4:2014 and AS 1530.4:2005 are not appreciably different.

Furnace pressure

The furnace pressure conditions for single and multiple penetration sealing systems in AS 1530.4:2005 and AS 1530.4:2014 are not appreciably different. The parameters outlining the accuracy of control of the furnace pressure in AS 1530.4:2014 and AS 1530.4:2005 are not appreciably different.

Furnace pressure regime

AS 1530.4:2014 and AS 1530.4:2005 specifies that a pressure of 15 ± 3 Pa shall be established at the centre of the lowest penetration service.

Specimen temperature measurement

The specification and location for specimen thermocouples in AS 1530.4:2014 are the same as those specified in AS 1530.4:2005.

Integrity performance criteria

AS 1530.4:2014 stipulates in addition to the 20 mm thick × 100 mm × 100 mm cotton pads, additional cotton pads shall be provided with a reduced 30 mm × 30 mm × 20 mm with additional wire frame holder and shall be used to determine integrity failure.

Apart from the above variation, the failure criteria for integrity in AS 1530.4:2014 and AS 1530.4:2005 are not appreciably different.

Insulation performance criteria

The insulation criteria specified in AS 1530.4:2014 are the same as those specified in AS 1530.4:2005.

Application of WFRA 41257.1 test data as to AS 1530.4:2014

The average pressure over a 5 minute period at various times during the test exceeded the maximum variation of ± 3Pa, the running average of pressure at all times during the test remained within the specified limits of variance, this variation is considered slightly more onerous than that required by the test standard and not considered to significantly affect the results of the test.

Upon commencement of the fire resistance test it had become evident that some thermocouples had become faulty, causing some services to not comply with the thermocouple locations specified in AS 1530.4:2014. The remaining thermocouples did however cover at least one point of the thermocouple locations specified in AS 1530.4:2014. Roving thermocouple readings were taken where possible. This variation is not considered to significantly affect the results of the test.

Based on the above discussion and in absence of any foreseeable integrity and insulation risk, it is concluded that the results relating to the integrity and insulation performance of the specimens – tested in WFRA 41257.1 – can be used to assess the integrity and insulation performance in accordance with AS 1530.4:2014. Therefore, cables and metal pipes tested in WFRA 41257.1 will likely achieve the FRL presented in Table 9 if tested in accordance with AS 1530.4:2014.

Table 9 Fire resistance performance of services penetrating a 150 mm thick steel reinforced CSR Hebel Powerpanel™ wall system

Item no.	Service	Sealing system	FRL
1	AS 1530.4:2014 Appendix D1 cables	The Firesound sealant must be applied to a depth of 10 mm on both the exposed and unexposed side from the separating element. A 50 mm × 50 mm fillet of the sealant must also be applied around the service on both exposed and unexposed sides of the separating element.	-/180/90
2	AS 1530.4:2014 Appendix D2 cables		-/180/120
3	PVC insulated copper cable	The Firesound sealant must be applied to a depth of 10 mm on both the exposed and unexposed side from the separating element. A 30 mm × 30 mm fillet of the sealant must also be applied around the service on both exposed and unexposed sides of the separating element.	-/180/180
4	22 mm (ID) steel sprinkler pipe with a wall thickness of 3mm		-/180/180
5	32mm (ID) steel sprinkler pipe with a wall thickness of 3mm		-/180/180
6	100mm (ID) copper pipe with a wall thickness of 2mm	The Firesound sealant must be applied to a depth of 10 mm on both the exposed and unexposed side from the separating element. A 50 mm × 50 mm fillet of the sealant must also be applied around the service on both exposed and unexposed sides of the separating element.	-/180/-
7	80mm (ID) steel sprinkler pipe with a wall thickness of 4mm		-/180/30

5.3.2 Performance of power cable penetrations in concrete floors protected by H B Fuller Firesound sealant

AS 1530.4:2014 Appendix D1 and D2 cables

AS 1530.4:2014 Appendix D1 power cables protected with H B Fuller Firesound sealant are tested in both 150 mm thick steel reinforced CSR Hebel Powerpanel™ walls and 150 mm thick concrete floors in WFRA 41257.1 and FRT200220 R1.0, respectively. D1 cables in the floor system achieved an FRL of -/240/60 when tested in accordance with AS 1530.4:2014. Integrity failure was not observed throughout the test duration of 241 minutes. D1 cables in the wall system did not show an integrity failure for at least up to 180 minutes until the test was terminated at 181 minutes.

AS 1530.4:2014 Appendix D2 cables protected with H B Fuller Firesound sealant tested in the wall system achieved an FRL of -/180/120 where no integrity failure was observed for 181 minutes at the time the test was terminated. Provided that both D1 and D2 cables in a wall system and D1 cables in a floor system maintained integrity performance for not less than 180 minutes with no failure at the time of the end of the tests - it is likely that D2 cables in a floor system with the same thickness will likely achieve an integrity performance of at least 180 minutes if tested in accordance with AS 1530.4:2014.

The insulation failure times for D1 and D2 cables tested in the wall system are 100 minutes and 149 minutes, respectively. It can be observed that D2 cables maintained the insulation performance for an additional 49 minutes compared to D1 cables, when tested in walls. D1 cables penetrating the floor system achieved an insulation performance of 60 minutes according to test report FRT200220 R1.0. Since D2 cables have better insulation performance compared to D1 cables which is proven in test report WFRA 41257.1, it is likely that D2 cables in the floor system will achieve at least around 40 minutes higher insulation rating than D1 cables.

Based on the discussion presented above, it is reasonable to expect that D2 cables in a floor system protected with H B Fuller Firesound sealant will likely achieve an FRL of -/180/90 if tested in accordance with AS 1530.4:2014.

PVC insulated copper cable

A PVC insulated copper cable achieved an FRL of -/180/180 when tested in a 150 mm thick wall system according to WFRA 41527.1. The copper cable showed no integrity failure during the test time of 181 minutes. Given that D1 standard cables were tested in both wall and concrete floor systems with 150 mm thickness and achieved an integrity performance of at least 180 minutes without any failure throughout the test duration, it is expected that the PVC insulated copper power cable will achieve at least 180 minutes integrity performance if tested in a 150 mm thick concrete floor system.

The PVC insulated copper cable did not fail the insulation performance criteria when tested in a 150 mm thick wall system for the duration of the test. The temperature on the thermocouple 25 mm from the sealant on the cable was recorded as 118 °C at 180 minutes when the test ended corresponding to a temperature rise of only 89 °C.

As discussed in the previous section, the D1 standard cables showed an insulation failure at 100 minutes when tested in a wall system and at 60 minutes when tested in floor system. The PVC insulated copper cable was able to maintain the insulation performance for an additional 80 minutes when tested in a wall system compared to the D1 cable. Given that the D1 cable achieved 60 minutes insulation performance when tested in a floor system and that the PVC insulated copper power cable did not fail the insulation criteria even after 180 minutes in a wall system, it is reasonable to expect the PVC insulated copper power cable will achieve an insulation performance of at least 120 minutes with an additional safety margin when tested in a 150 mm thick floor system.

Based on the above discussion, it is likely that the proposed PVC insulated copper cable in a 150 mm thick floor system protected with H B Fuller Firesound sealant will achieve an FRL of -/180/120 if tested in accordance with AS 1530.4:2014.

5.3.3 Performance of metal pipe penetrations in concrete floors

100 (ID) copper pipe with 2 mm wall thickness

The tested services in FRT200220 R1.0 consisted of a DN (diameter nominal) 100 mm copper pipe with an outside diameter (OD) of 101.6 mm and a wall thickness of 2.03 mm in a concrete floor protected with H B Fuller Firesound sealant. The copper pipe achieved an FRL of -/240/15 when tested in accordance with AS 1530.4:2014. The tested copper pipe did not fail the integrity criteria by the end of the test at 241 minutes, whereas it reached the insulation threshold after 24 minutes. According to AS 1530.4:2014 section 10 – results of the above specimen may be applied to pipes of the same material having an outside diameter not greater than the tested diameter and a thickness not less than the tested thickness. Therefore, a copper pipe with an internal diameter of 100 mm and a wall thickness of 2 mm is proposed to be assessed based on the results of the tested specimen. As the variation in outside diameter and thickness of the proposed pipe are insignificant compared to the tested specimen, it is likely to achieve an FRL of -/240/15 similar to the tested DN 100 mm copper pipe if tested in accordance with AS 1530.4:2014.

22 (ID) steel pipe with 3 mm wall thickness

A copper pipe with an OD of 25.4 mm and thickness 1.22 mm (DN 25 copper pipe) in a concrete floor protected with H B Fuller Firesound sealant achieved an FRL of -/240/90 when tested in accordance with AS 1530.4:2014 in FRT200220 R1.0. The tested copper pipe did not fail the integrity criteria by the end of the test at 241 minutes, whereas it reached the insulation threshold after 100 minutes.

According to AS 1530.4:2014 section 10, results of the above specimen may be applied to pipes of the same material and to ferrous (steel) metal pipes having an outside diameter not greater than the tested diameter and a thickness not less than the tested thickness. Generally, the melting point of steel metal pipes are higher than that of copper pipes. Thus, steel pipes are unlikely to excessively soften or melt. Therefore, the risk of integrity failure due to the formation of through gaps, sustained flaming or the passage of hot gasses or smoke from the exposed side to the unexposed side is not increased with the use of steel pipes.

The conductivity of steel is also much lower than that of copper pipes. Hence, steel pipes of the same size are unlikely to heat up to the same level as a copper pipe. Therefore, the risk of insulation failure is also reduced. Overall, it is likely that the assessment outcomes specified for the DN 25 copper pipe tested in FRT200220 R1.0 can be applied to the proposed steel pipe based on the above discussion obtained from the information presented and discussed in AS 4072.1:2005. As the increase in outside diameter of the proposed pipe is insignificant compared to the reduction in conductivity of steel, the 22 (ID) steel pipe with 3 mm wall thickness is likely to achieve an FRL of -/240/90 if tested in accordance with AS 1530.4:2014.

32 (ID) steel pipe with 3 mm wall thickness

The DN 32 copper pipe with an OD of 31.75 mm and a wall thickness of 0.91 mm obtained an FRL of -/240/120 as reported in FRT200220 R1.0. Similar to the discussion presented on the steel pipe with an internal diameter of 22 mm in the previous section, the FRL of the proposed steel pipe with an internal diameter of 32 mm and a wall thickness of 3 mm is likely to have a similar FRL as obtained for the DN 32 copper pipe tested in FRT200220 R1.0.

Therefore, the proposed steel pipe with an internal diameter of 32 mm and a wall thickness of 3 mm is expected to achieve an FRL of -/240/120 if tested in accordance with AS 1530.4:2014.

80 (ID) steel pipe with 4 mm wall thickness

The DN 100 copper pipe with an OD of 101.6 mm and a wall thickness of 2.03 mm obtained an FRL of -/240/15 as reported in FRT200220 R1.0. Similar to the discussion presented on the steel pipe with an internal diameter of 22 mm in the previous section, the FRL of the proposed steel pipe with an internal diameter of 80 mm and a wall thickness of 4 mm is likely to have at least an FRL obtained for the DN 100 copper pipe tested in FRT200220 R1.0.

Therefore, the proposed steel pipe with an internal diameter of 80 mm and a wall thickness of 4 mm is expected to achieve an FRL of -/240/15 if tested in accordance with AS 1530.4:2014.

DN 32 mm copper, brass and steel pipes

Brass pipes generally have similar melting point and lower thermal conductivity than copper pipes. Therefore, it is expected that brass pipes will perform at least similarly or better than copper pipes. Further confidence in such conclusion is gained from test observations for DN 100 mm brass pipe in FRT200220 R1.0 where it achieved an FRL of -/240/30. The melting point of steel pipes are higher than that of copper pipes. Thus, steel pipes are unlikely to excessively soften or melt. Therefore, the risk of integrity failure due to the formation of through gaps, sustained flaming or the passage of hot gasses or smoke from the exposed side to the unexposed side is not increased with the use of steel pipes. The thermal conductivity of steel is also much lower than that of copper pipes. Hence, steel pipes of the same size are unlikely to heat up or transfer heat across to the same level as a copper pipe. Therefore, the risk of insulation failure is also reduced.

Overall, it is likely that the assessment outcomes specified for the DN 32 copper pipe tested in FRT200220 R1.0 can be applied to brass and steel pipes of the same size. Based on the above discussion it is concluded that copper, brass and steel metal pipes of DN 32 mm will achieve an FRL of -/240/120.

DN 40 to DN 100 mm copper, brass and steel pipes

Similar to the discussion in the previous section, copper, brass and steel pipes with nominal diameters 40 mm – 100 mm with thicknesses as specified in Table 12 will achieve an FRL as same as the DN 100 mm copper pipe tested in FRT200220 R1.0, which is -/240/15.

DN 125 to DN 150 mm copper and steel pipes

With reference to the discussion in the section on 22 (ID) steel pipe the FRL of DN 125 to DN 150 mm copper and steel pipes with thicknesses as specified in Table 12 can be assessed based on test data obtained for DN 200 copper pipe tested in FRT200220 R1.0. DN 200 mm copper pipe failed the integrity criteria after 228 minutes – igniting a cotton pad at the interface of the sealant to service. Moreover, the DN 200 mm copper pipe failed to maintain its insulation threshold after 17 minutes as thermocouple on the service, 25 mm from the sealant recorded a temperature of 202 °C – resulting in an FRL of -/180/15. Therefore, it is expected that copper and steel pipes with DN 125 mm to DN 150 mm will likely achieve an FRL similar to the DN 200 mm copper pipe tested in FRT200220 R1.0 - which is -/180/15.

5.4 Conclusion

This assessment demonstrates that various cable and metal pipe penetrations protected by H B Fuller Firesound sealant are likely to achieve the FRLs given in Table 10 to Table 12 – if they were tested in accordance with AS 1530.4:2014.

Table 10 Assessment summary of services penetrating a 150 mm thick AAC/concrete wall

Item no.	Service	Sealing system	FRL
1	AS 1530.4:2014 Appendix D1 cables	The Firesound sealant must be applied to a depth of 10 mm on both the exposed and unexposed side from the separating element. A 50 mm × 50 mm fillet of the sealant must also be applied around the service on both exposed and unexposed sides of the separating element.	-/180/90
2	AS 1530.4-2014 Appendix D2 cables		-/180/120
3	PVC insulated copper cable	The Firesound sealant must be applied to a depth of 10 mm on both the exposed and unexposed side from the separating element. A 30 mm × 30 mm fillet of the sealant must also be applied around the service on both exposed and unexposed sides of the separating element.	-/180/180
4	22 mm (ID) steel sprinkler pipe with a wall thickness of 3 mm		-/180/180
5	32mm (ID) steel sprinkler pipe with a wall thickness of 3 mm	The Firesound sealant must be applied to a depth of 10 mm on both the exposed and	-/180/180

Item no.	Service	Sealing system	FRL
6	100mm (ID) copper pipe with a wall thickness of 2 mm	unexposed side from the separating element. A 50 mm × 50 mm fillet of the sealant must also be applied around the service on both exposed and unexposed sides of the separating element.	-/180/-
7	An 80mm (ID) steel sprinkler pipe with a wall thickness of 4 mm		-/180/30

Table 11 Assessment summary of cable services penetrating a 150 mm concrete floor

Item no.	Cable services	Sealing system	FRL
1	AS 1530.4:2014 Appendix D1 cables	The Firesound sealant must be applied to a depth of 10 mm on both the exposed and unexposed side from the separating element. A 50 mm × 50 mm fillet of the sealant must also be applied around the service on both exposed and unexposed sides of the separating element.	-/240/60
2	AS 1530.4-2014 Appendix D2 cables		-/180/90
3	PVC insulated copper cable		-/180/120

Table 12 Assessment summary of metal pipe services penetrating a 150 mm concrete floor

Item no.	Metal pipe (mm)	Material	Wall thickness (mm)	Sealing system	FRL
1	22 (ID)	Steel	3.0	The Firesound sealant must be applied to a depth of 20 mm on both the exposed and unexposed side from the separating element. A 50 mm × 50 mm fillet of the sealant must also be applied around the service on both exposed and unexposed sides of the separating element.	-/240/90
2	32 (ID)	Steel	3.0		-/240/120
3	80 (ID)	Steel	4.0		-/240/15
4	DN 32	Copper, brass, steel	0.91		-/240/120
5	DN 40 -DN 65	Copper, brass, steel	0.91		-/240/15
6	DN 80 – DN 100	Copper, brass, steel	1.22		-/240/15
7	100 (ID)	Copper	2.0		-/240/15
8	DN 125	Copper, steel	1.42	The Firesound sealant must be applied to a depth of 20 mm on both the exposed and unexposed side from the separating element. A 50 mm × 50 mm fillet of the sealant must also be applied around the service on both exposed and unexposed sides of the separating element.	-/180/15
9	DN 150	Copper, steel	1.63		-/180/15

6. Validity

Warringtonfire Australia does not endorse the tested or assessed product in any way. The conclusions of this assessment may be used to directly assess fire hazard, but it should be recognised that a single test method will not provide a full assessment of fire hazard under all conditions.

Due to the nature of fire testing and the consequent difficulty in quantifying the uncertainty of measurement, it is not possible to provide a stated degree of accuracy. The inherent variability in test procedures, materials and methods of construction, and installation may lead to variations in performance between elements of similar construction.

This assessment is based on information and experience available at the time of preparation. The published procedures for the conduct of tests and the assessment of test results are subject to constant review and improvement. It is therefore recommended that this report be reviewed on, or before, the stated expiry date.

This assessment represents our opinion about the performance likely to be demonstrated on a test in accordance with AS 1530.4:2014, based on the evidence referred to in this report.

This assessment is provided to H B Fuller Australia Pty Ltd for their own specific purposes. Building certifiers and other third parties are responsible for deciding if they accept this assessment in a particular context.

Appendix A Drawings and additional information

Table 13 Details of drawings

Figure No	Drawn
Figure 1 to Figure 5	Extracted from assessment report 27001-03
Figure 6 to Figure 7	Extracted from FRT200220 R1.0

Appendix B Summary of supporting test data

B.1 Test report – WFRA 41257.1

Table 14 Information about test report

Item	Information about test report
Report sponsor	H B Fuller Australia Pty Ltd
Test laboratory	Warrington Fire Research Aust Pty Ltd, Unit 2, 409-411 Hammond Road, Dandenong, Victoria 3175, Australia.
Test date	The fire resistance test was completed on 11 October 2006.
Test standards	The test was done in accordance with AS 1530.4:2005.
Variation to test standards	<ol style="list-style-type: none"> 1. The average pressure over a 5 minute period at various times during the test exceeded the maximum variation of $\pm 3\text{Pa}$, the running average of pressure at all times during the test remained within the specified limits of variance. This variation is considered slightly more onerous than that required by the test standard and not considered to significantly affect the results of the test. 2. Upon commencement of the fire resistance test it had become evident that some thermocouples had become faulty, causing some services not to comply with the thermocouple locations specified in AS 1530.4:2005. The remaining thermocouples did however cover at least one point of the thermocouple locations specified in AS 1530.4:2005. Roving thermocouple readings were taken where possible. This variation is not considered to significantly affect the results of the test.
General description of tested specimen	The test assembly comprised a nominal 1300mm wide x 1250mm x 150mm thick steel reinforced CSR Hebel Powerpanel™ wall system penetrated by the standard cable configurations for the evaluation of electrical and telecommunications cables and various sized metal pipes protected by H B Fuller Firesound sealant.
Instrumentation	The test report states that the instrumentation was in accordance with AS 1530.4:2005.

All the service penetrations except Service A are relevant to this assessment, the details of which are provided below in Table 15.

Table 15 Test specimens

Service	Description	Protection
B	AS1530.4-2014 Appendix D2 cables (standard configuration)	Foam backing rod was positioned in the annular gap a nominal 10 mm back from both sides of the wall face. HB Fuller FIRESOUND sealant was used on both sides and was applied around the annular gap to the backing rod.
C	Single PVC insulated copper telecommunication cable	Foam backing rod was positioned in the annular gap a nominal 10 mm back from both sides of the wall face. HB Fuller FIRESOUND sealant was used on both sides and was applied around the annular gap to the backing rod.
D	A 22mm (ID-measured) steel sprinkler pipe with a wall thickness of 3mm (measured).	Foam backing rod was positioned in the annular gap a nominal 10mm back from both sides of the wall face. HB Fuller FIRESOUND sealant was used on both sides and was applied around the annular gap to the backing rod.
E	A 32mm (ID-measured) steel sprinkler pipe with a wall thickness of 3mm (measured).	Foam backing rod was positioned in the annular gap a nominal 10mm back from both sides of the wall face. HB Fuller FIRESOUND sealant was used on both sides and was applied around the annular gap to the backing rod.
F	A 100mm (ID-measured) copper pipe with a wall thickness of 2mm (measured)	Foam backing rod was positioned in the annular gap a nominal 10mm back from both sides of the wall face. HB Fuller FIRESOUND sealant was used on both sides and was applied around the annular gap to the backing rod.

Service	Description	Protection
G	An 80mm (ID-measured) steel sprinkler pipe with a wall thickness of 4mm (measured)	Foam backing rod was positioned in the annular gap a nominal 10mm back from both sides of the wall face. HB Fuller FIRESOUND sealant was used on both sides and was applied around the annular gap to the backing rod.
H	AS1530.4-2014 Appendix D1 cables (standard configuration)	Foam backing rod was positioned in the annular gap a nominal 10mm back from both sides of the wall face. HB Fuller FIRESOUND sealant was used on both sides and was applied around the annular gap to the backing rod.

The test specimens achieved the following results – see Table 16.

Table 16 Results summary for this test report

Service	Criteria	Result	FRL
B	Integrity	No failure at 181 minutes	-/180/120
	Insulation	149 minutes	
C	Integrity	No failure at 181 minutes	-/180/180
	Insulation	No failure at 181 minutes	
D	Integrity	No failure at 181 minutes	-/180/180
	Insulation	No failure at 181 minutes	
E	Integrity	No failure at 181 minutes	-/180/180
	Insulation	No failure at 181 minutes	
F	Integrity	No failure at 181 minutes	-/180/-
	Insulation	14 minutes	
G	Integrity	No failure at 181 minutes	-/180/30
	Insulation	41 minutes	
H	Integrity	No failure at 181 minutes	-/180/90
	Insulation	100 minutes	

B.2 Test report – FRT200220 R1.0

Table 17 Information about test report

Item	Information about test report
Report sponsor	H B Fuller Australia Pty Ltd
Test laboratory	Warringtonfire Australia, Unit 2, 409-411 Hammond Road, Dandenong, Victoria 3175, Australia.
Test date	The fire resistance test was completed on 23 November 2020.
Test standards	The test was done in accordance with AS 1530.4:2014.
Variation to test standards	The pressure was up to 1 Pa below the limits prescribed in the standard during the 225-230 minute period. The pressure and temperature were within the limits for the rest of the test. Due to the nature of the specimen and the fact that no significant events occurred during this time period, this under pressure is unlikely to have invalidated the test results.
General description of tested specimen	The test assembly comprised a nominal 1760 mm long × 1200 mm wide × 150mm thick concrete floor slab penetrated by standard cable configurations and various sized metal pipes protected by HB Fuller Firesound sealant.
Instrumentation	The test report states that the instrumentation was in accordance with AS 1530.4:2014.

All the service penetrations except Service D are relevant to this assessment, the details of which are provided below in Table 18.

Table 18 Test specimens

Service	Description	Protection
A	D1 power cable group and 300 mm cable tray	A backing rod (item 2) was installed into the annular gap between the service and the separating element at a depth of 10 mm from the separating element on both the unexposed and exposed sides. The Firesound sealant (item 3) was then applied to the depth of the backing rod – that is, to 10 mm. A 50 mm × 50 mm fillet of sealant was also applied around the service on both the exposed and unexposed sides of the separating element.
B	DN 32 type D copper pipe, outer diameter 31.75 mm, thickness 0.91 mm	A backing rod (item 2) was installed into the annular gap between the service and the separating element at a depth of 10 mm from the separating element on both the unexposed and exposed sides. The Firesound sealant (item 3) was then applied to the depth of the backing rod – that is, to 10 mm. A 50 mm × 50 mm fillet of sealant was also applied around the service on both the exposed and unexposed sides of the separating element.
C	DN 100 type A copper pipe, outer diameter 101.6 mm, thickness 2.03 mm	A backing rod (item 2) was installed into the annular gap between the service and the separating element at a depth of 10 mm from the separating element on both the unexposed and exposed sides. The Firesound sealant (item 3) was then applied to the depth of the backing rod – that is, to 10 mm. A 50 mm × 50 mm fillet of sealant was also applied around the service on both the exposed and unexposed sides of the separating element.
E	DN 200 type B copper pipe, outer diameter 203.2 mm, thickness 2.03 mm	A backing rod (item 2) was installed into the annular gap between the service and the separating element at a depth of 20 mm from the separating element on both the unexposed and exposed sides. The Firesound sealant (item 3) was then applied to the depth of the backing rod – that is, to 20 mm. A 50 mm × 50 mm fillet of sealant was also applied around the service on both the exposed and unexposed sides of the separating element.
F	DN 25 type B copper pipe, outer diameter 25.4 mm, thickness 1.22 mm	A backing rod (item 2) was installed into the annular gap between the service and the separating element at a depth of 20 mm from the separating element on both the unexposed and exposed sides. The Firesound sealant (item 3) was then applied to the depth of the backing rod – that is, to 20 mm. A 50 mm × 50 mm fillet of sealant

Service	Description	Protection
		was also applied around the service on both the exposed and unexposed sides of the separating element.
G	DN 100 brass pipe, outer diameter 101.6 mm, thickness 2.02 mm	A backing rod (item 2) was installed into the annular gap between the service and the separating element at a depth of 20 mm from the separating element on both the unexposed and exposed sides. The Firesound sealant (item 3) was then applied to the depth of the backing rod – that is, to 20 mm. A 50 mm x 50 mm fillet of sealant was also applied around the service on both the exposed and unexposed sides of the separating element.

The test specimen achieved the following results – see Table 19.

Table 19 Results summary for this test report

Service	Criteria	Results	FRL
A	Integrity	No failure at 241 minutes	-/240/60
	Insulation	Failure at 60 minutes	
B	Integrity	No failure at 241 minutes	-/240/120
	Insulation	Failure at 127 minutes	
C	Integrity	No failure at 241 minutes	-/240/15
	Insulation	Failure at 24 minutes	
E	Integrity	Failure at 228 minutes	-/180/15
	Insulation	Failure at 17 minutes	
F	Integrity	No failure at 241 minutes	-/240/90
	Insulation	Failure at 100 minutes	
G	Integrity	No failure at 241 minutes	-/240/30
	Insulation	Failure at 37 minutes	

warringtonfire

Proud to be part of  element



Warringtonfire Australia Pty Ltd
ABN 81 050 241 524

Perth

Unit 22, 22 Railway Road
Subiaco WA 6008
Australia
T: +61 8 9382 3844

Canberra

Unit 10, 71 Leichhardt Street
Kingston ACT 2604
Australia
T: +61 2 6260 8488

Sydney

Suite 802, Level 8, 383 Kent Street
Sydney NSW 2000
Australia
T: +61 2 9211 4333

Brisbane

Suite 6, Level 12, 133 Mary Street
Brisbane QLD 4000
Australia
T: +61 7 3238 1700

Melbourne – NATA registered laboratory

Unit 2, 409-411 Hammond Road
Dandenong South VIC 3175
Australia
T: +61 3 9767 1000

General conditions of use

The data, methodologies, calculations and results documented in this report specifically relate to the tested specimen/s and must not be used for any other purpose. This report may only be reproduced in full. Extracts or abridgements must not be published without permission from Warringtonfire.

All work and services carried out by Warringtonfire are subject to, and conducted in accordance with our standard terms and conditions. These are available on request or at <https://www.element.com/terms/terms-and-conditions>.